

TRIP CIRCUIT SUPERVISION RELAY TSG 910 flush mounted

The type TSG 910 relay supervises the trip circuit of circuit breaker and it activates delayed alarm and visual indication in the event of trip circuit failure or mechanism malfunction. The relays are available for all kinds of circuit breakers and for any combination of standard trip and alarm voltages.

Two limiting resistors are supplied separately with the relay type TSG 910 .. X .. If the relay is accidentally short circuited they provide current limitation which will not result in trip coil operation. These resistors are to be mounted in the trip circuit, outside the relay, so that stringent safety requirements are maintained.

Limiting resistors are mounted inside the relay type TSG .. N .. in applications where less stringent safety requirements may be observed. (For 220 V, the relays are delivered with external resistors only.)

Detected failures

After a 400 ms delay, the relay activates an alarm and visual indication in the event of the following failures:

- Trip voltage failure
- Trip coil interruption
- Trip circuit wiring interruption
- Circuit breaker malfunction
- Alarm voltage failure

Design

The relays and visual indicator are of rugged and proven construction mounted in a phenolic housing with screw terminals. The case is available for flush mounting.

The monitoring relay AB has two separate windings (dielectric strength: 2,5 kV) capable of attracting relay AB individually or in series. The alarm relay C has one NO and two NC contacts for alarm functions and a release time of greater than 400 ms.

The visual indicator is activated in the event of a failure; it can only be reset manually.

Function

The Relay TSG 910 .. X and TSG 910 .. N must be connected according to wiring diagrams 1 and 2, respectively.

Under healthy conditions and with the circuit breaker closed, the monitoring relay AB is attracted via winding 3-2 (winding 4-1 is



disconnected by the NC auxiliary contact of the circuit breaker). Alarm relay C is attracted by the contact of relay AB. Alarm voltage is applied on visual indicator coil S by the NO contact of relay C. The visual indicator can now be reset manually.

Winding 3-2 of the monitoring relay detects any failure in the trip circuit and the relay releases. Relay C also releases after 400 ms, resulting in activation of the alarm and visual indicator.

Under healthy conditions and with the circuit breaker open, the monitoring relay is attracted by both windings 3-2 and 4-1 in series by means of the NC auxiliary contact of the circuit breaker. The relay AB detects any trip circuit failures in the same manner as described above with the circuit breaker closed.

The visual indicator remains in the alarm status even after the malfunction is remedied, thus indicating a previous, short-term failure. The relays AB and C are delayed on drop-off for a total of 400 ms to prevent a false alarm resulting from brief voltage dips. In addition, the alarm cannot be activated during a normal tripping operation, when windings 3-2 of relay AB is momentarily short circuited by the trip relay contact. However, the alarm is activated if the trip relay fails to reset due to a failure of the circuit breaker tripping mechanism.

Wiring diagram 1 (external resistors)

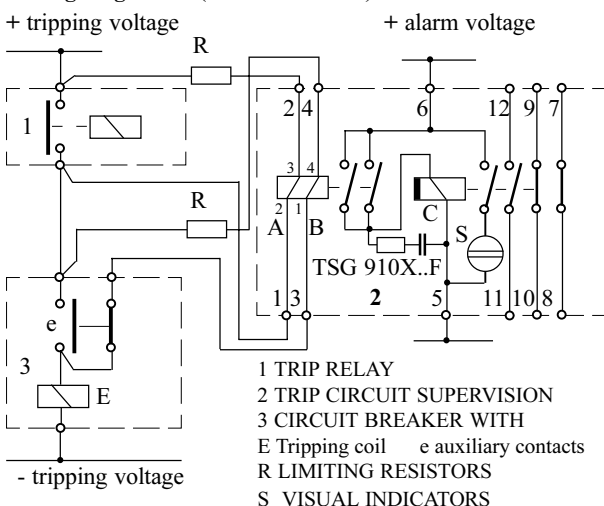

Wiring diagram 2 (internal resistors)

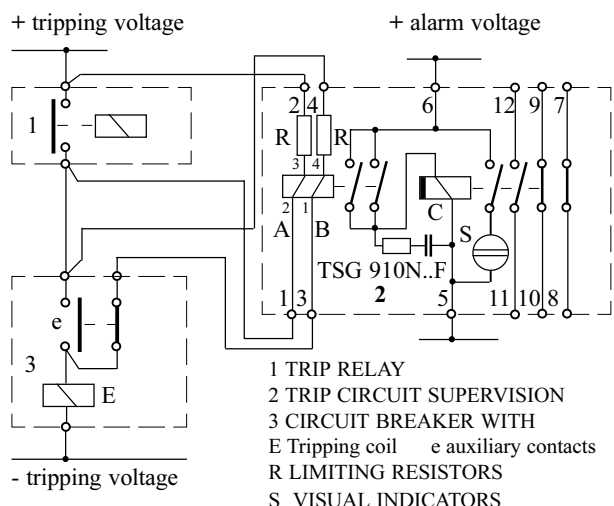

Voltage range

The relays TSG 910 are available for all combinations of the following trip and alarm voltages:

60V= 110V= 125V= 220V=
max. permissible line resistance 400 Ohm

LIMITING RESISTORS

Two separate limiting resistors are supplied with the relay TSG 910 .. X .. and have the following values:

tripping voltage	limiting resistor
60 V=	1600 \square
110 V=	3000 \square
125 V=	3600 \square
220 V=	8900 \square

TECHNICAL SPECIFICATIONS

Trip circuit

tripping voltages $\square 20\%$ 60 - 110 - 125 - 220 V=

operating power at	60V	1,3 Watt
	110 V	2,3 Watt
	125 V	2,7 Watt
	220 V	4,3 Watt

limiting current at short circuit <40 mA
max. permissible line resistance 400 Ohm

Alarm circuit

alarm voltages 60 - 110 - 125 - 220 V= $\square 20\%$

power input at	60 V	2,1 Watt
	110 V	2,3 Watt
	125 V	2,5 Watt
	220 V	4,3 Watt

alarm delay > 400 ms.

Visual indicator

display opto-mechanical

Alarm Relay C

test VDE 0453/9.72
contacts Ag gold plated 2 x NC + 1 x NO

contact load
250V~ 3A cos \square
250V~ 1A cos \square
250V- 0,4A (0 mS)
250V- 0,2A (40 mS)

General specifications

ambient temperature range -20° ÷ +80°C
dielectric strength 2500 V RMS 50 Hz 1 Min.
isolation test about IEC60255-5 and ANSI/IEE C37.90
weight with internal resistors 580 gr
weight without resistors 550 gr
weight of an external resistor 100 gr

Housing

insulation VDE 0110-7.50 380 VE 440 VG
protection class IP 40
IP 51 with transparent cover
terminals 2,5 mm² with wire seal
Brennverhalten nach UL 94 V-1

External limiting resistor

resistor values see table $\pm 10\%$
terminals 4 mm² with wire seal
dielectric strength 2500 V RMS 50 Hz 1 Min.

TYPE DESIGNATION - ORDER SPECIFICATION

	TSG 910	X	11	A	12
Series					
Limiting resistor	external X				
(220V Type only with ext. res)	internal N				
Tripping voltage x10	60 V= 06				
	110 V= 11				
	125 V= 12				
	220 V= 22				
Alarm voltage x10	A				
	60V= 06				
	110 V= 11				
	125 V= 12				
	220 V= 22				

Housing dimensions

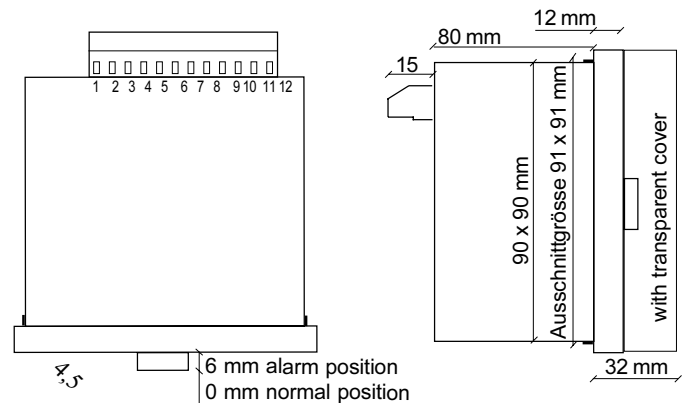
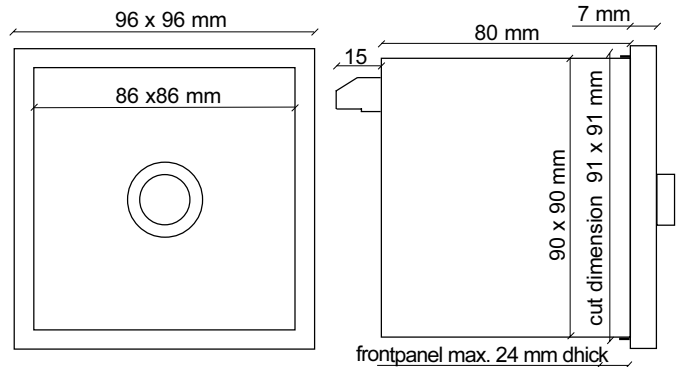

Dimensions of external limiting resistor
Execution 'Standard'

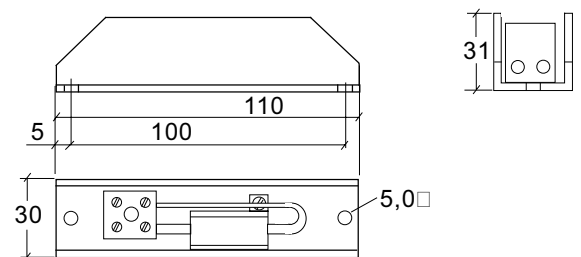

Dimensions of external limiting resistor
Very special execution for mounting on DIN rail

